

## SHOALS™ CABLE MANAGEMENT SOLUTION TORQUE TOOL

### FEATURES

- Lightweight and compact
- Designed with a built-in gauge that controls the tension applied to the wire
- Works with wire up to 6mm diameter
- Ensures consistent tension every time, optimising the life of the wires
- Gear-driven handles provide a 6:1 mechanical advantage, which allows tensioning with minimal effort

### TIPS

- If installing on a post which is “open-side-out”, there is a handy adapter that can be fitted to the tool to make tensioning easier
- Regularly lubricate the cam area for smooth operation
- Replacement cam sets are available should the teeth wear



### INSTALLATION

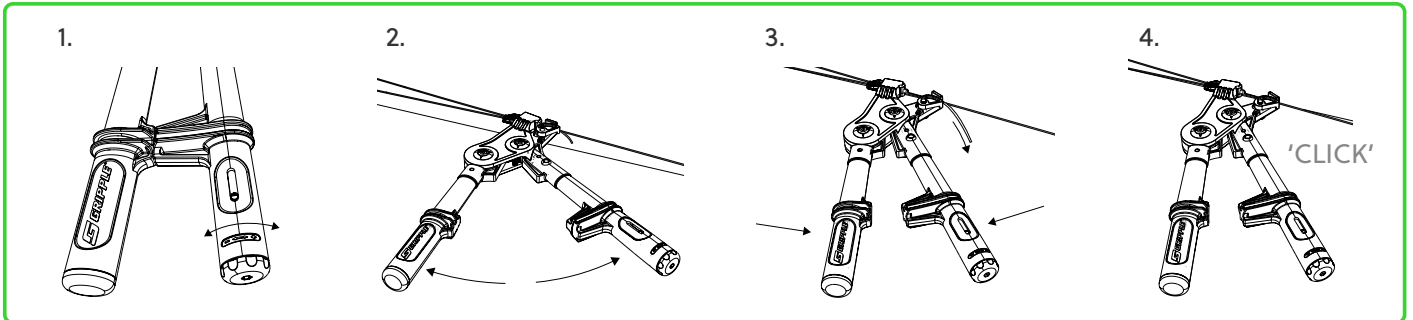

#### SPECIFICATIONS

Wire Range

Tension Gauge Range

Max Working Load

#### WMS00011

Up to 1/4" / 6mm diameter

200lb-660lb / 100kg-300kg

880lb / 400kg